

Percussion Workstation

- Basic Percussion Workstation 147G002._ 230 lbs (104 kg).
- Deluxe Percussion Workstation with all accessories 147G001._ 251 lbs (113 kg) 230 lbs.
- Workstation is 48-1/8" wide x 24-1/2" deep x 35-3/4" high (1222 x 622 x 908 mm).
- Workstation construction is 3/4" (19 mm) thick industrial grade composite wood with no added formaldehyde and polyester laminate finish in Wenger standard colors.
- Edging is 1/8" (3 mm) radiused PVC.
- Workstation top is 3/4" (19 mm) industrial grade composite wood with industrial grade carpet on top.
- Plywood bottom is 3/4" (19 mm) with four 4" (102 mm) rubber swivel casters that make it easy to move from room to room.
- Workstation has four foam-lined 21-1/2" wide x 19-3/4" deep x 3-1/2" high (546 x 502 x 89 mm) drawers constructed of 18 gauge steel with built-in handle.
- Four 23" wide x 23" deep (584 x 584 mm) compartments, 3-1/2" (89 mm) high and 15-3/4" high (400 mm).
- UL GREENGUARD Certified - Product certified for low chemical emissions: ul.com/gg - UL 2818.
- Environmental attributes and LEED compliance for this product can be found at www.wengercorp.com/GREEN or by contacting your Wenger representative.
- Shipped assembled.
- Ten-year warranty.

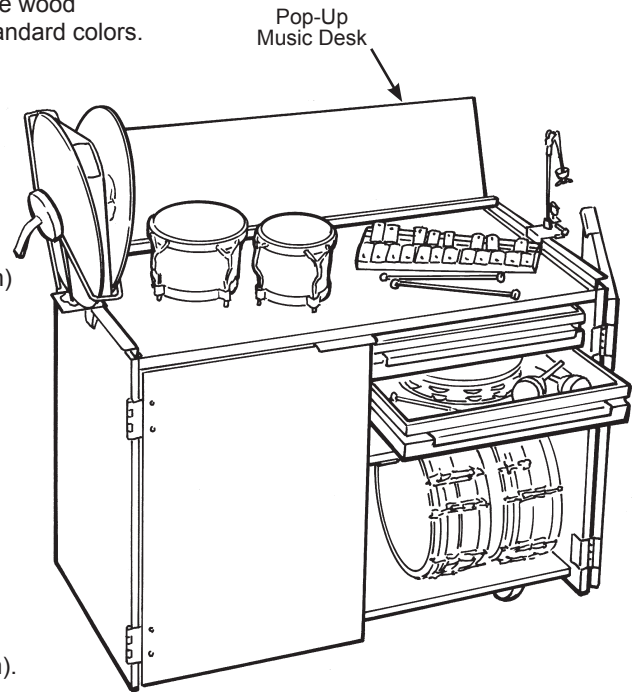

Accessories

Pop-up Music Desk

- 147H510._ 17.7 lbs. (7.7 kg).
- Holds music for three or more people.
- Desk is 46-1/8" wide x 1-7/16" deep x 10-3/4" high (1172 x 37 x 273 mm).
- Desk construction is 3/4" (19 mm) thick industrial grade composite wood with polyester laminate finish in Wenger standard colors.
- Desk permanently attaches to work top and folds flat when not in use.

Suspended Cymbal Holder

- 147H014 2 lbs. (0.9 kg).
- Adjustable vinyl-coated holder clamps to cabinet edge.

Cymbal Cradle

- 147H012 7 lbs. (3 kg).
- Holds up to 22" (559 mm) cymbals in ready-to-use position.
- Vinyl-coated cradle, which protects and holds cymbals quietly, clamps to the cabinet edge.

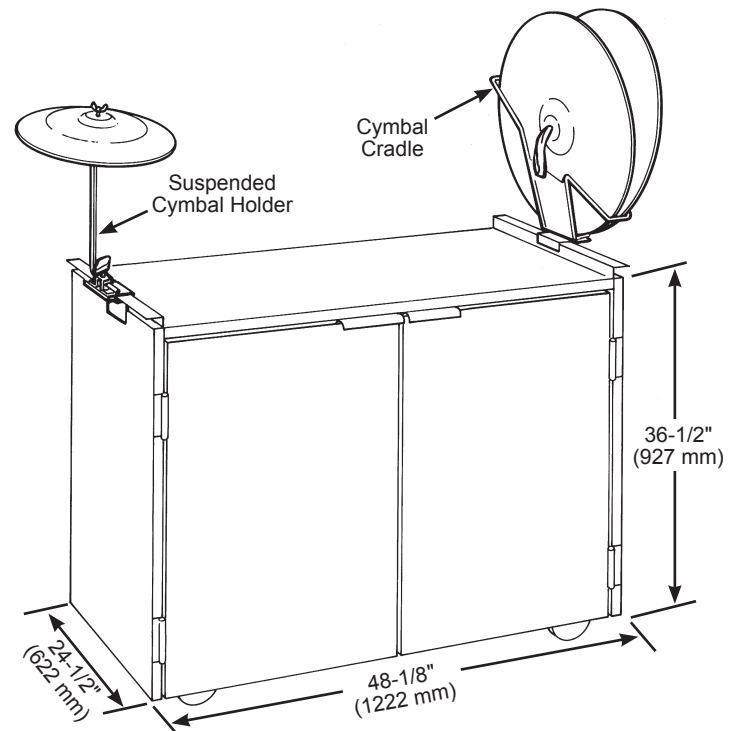

© 2017 Wenger Corporation
USA/2017-12/W



WENGER CORPORATION

Phone 800.4WENGER (493-6437) Worldwide +1.507.455.4100 | Fax 507.455.4258 Worldwide +1.507.774.8576
Parts & Service 800.887.7145 | Canada Office 800.268.0148 | Web wengercorp.com | 555 Park Drive, PO Box 448 | Owatonna | MN 55060-0448

JR CLANCY

Phone 800.836.1885 Worldwide +1.315.451.3440 | Fax 877.836.1885 Worldwide +1.315.451.1766 | Web jrclancy.com
7041 Interstate Island Road | Syracuse | NY 13209-9713

GEARBOSS

Phone 800.493.6437 | email gearboss@wengercorp.com | Web gearboss.com | 555 Park Drive, PO Box 448 | Owatonna | MN 55060-0448