

Preface® Music Stand

- 237B500 Preface Music Stand 5.7 lb (2.9 kg)
- 13-1/2" x 20" (343 x 508 mm) lightweight, aluminum desk with one piece aluminum attachment bracket
- 14-gauge steel base
- Wobble-free base attachment
- 1" (25 mm) steel upright post for easy transport
- Bolt-through desk attachment to prevent desk from coming off unexpectedly
- Recessed desk lip area allows stand to be stored on cart without having to flip the desk
- Durable black powder-coat paint finish
- Brass spring height adjuster adjusts height from 25" to 49" (635 to 1245 mm) (desk lip to floor)
- UL GREENGUARD Certified - Product certified for low chemical emissions: ul.com/gg - UL 2818
- Ten-year warranty

Accessories

Electric Music Stand Light

Classic stand light fits all Wenger stands, and most other manufacturers' stands

- 1090001 Music Stand Light, 14 oz (0.4 kg)

LED Music Stand Lights

Compact, attractive, and adjustable, these battery-operated stand lights work with all Wenger stands; features all-LED technology, so no bulbs to replace

- 237A040 HammerHead LED Music Stand Light, 2.1 oz (0.06 kg)
- 237A035 Encore LED Music Stand Light, 4.3 oz (0.12 kg)
- 237A033 Orchestra Music Stand Light, 10.2 oz (0.29 kg)

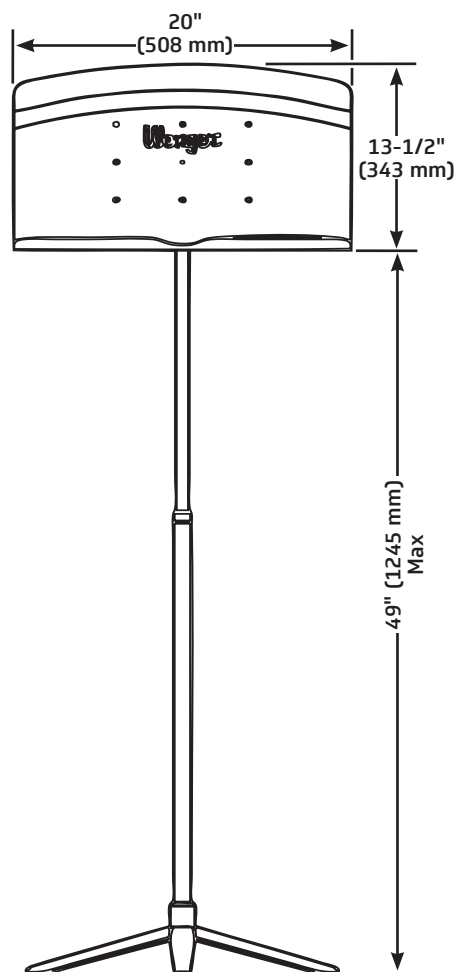
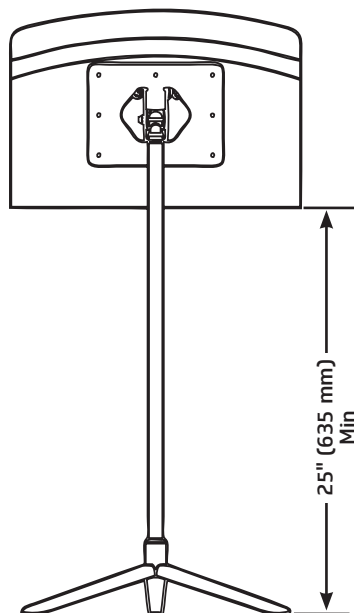
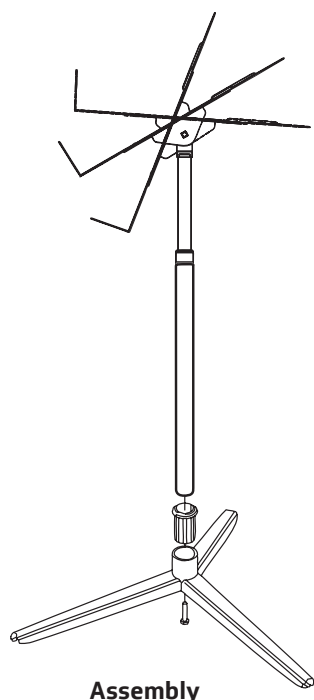

Accessories (continued)

Hands-Free Page Turner

A rugged hands-free device for turning the pages on your digital sheet music; simple setup and operation make this a great solution for musicians who need a hand

- 040A142, 0.55 lb (0.24 kg)
 - Tap the foot switches to turn the pages on your digital sheet music forward or backward
 - No messy cables, wireless connection to tablets or computers up to 60' (18 m) away using secure Bluetooth technology
 - Internal rechargeable battery, up to 100 hours between charges
 - Nearly indestructible, made of same material as bullet-proof glass



Hands-Free Page Turner

Universal Tablet Mount, Single

The perfect holder for most models of tablets, clipping your tablet in place is easy and secure; no more resting your tablet on a stand, amp, floor, etc.

- 040A154, 15 oz (0.42 kg)
 - Attaches to a standard 5/8" (16 mm) threaded stand

Large Stand Move & Store Cart

- 039C202, 38 lb (17.2 kg)
 - Holds twenty Preface Stands without flipping the desk; maximize cart storage by flipping the desk, holds twenty four
 - Large center pivot wheels for maneuverability
 - Loads and unloads from both ends
 - 14-gauge 1" x 1-1/2" (25 x 38 mm) and 16-gauge 7/8" (22 mm) steel tubing with 8" (203 mm) wheels and 5" (127 mm) heavy-duty casters
 - Stores compactly in 27-1/2" x 68" (699 x 1727 mm) floor space; allow 61" (1549 mm) for height with Preface Stands

Small Stand Move & Store Cart

- 039D201, 21 lb (9.5 kg)
 - Holds ten Preface Stands without flipping the desk; maximize cart storage by flipping the desk, holds twelve
 - Two-wheel cart design allows transport up and down stairs
 - 14-gauge 1" x 1-1/2" (25 x 38 mm) and 16-gauge 7/8" (22 mm) steel tubing with 8" (203 mm) heavy-duty wheels
 - Stores compactly in 27 1/2" x 36" (699 x 914 mm) floor space; allow 61" (1549 mm) for height with Preface Stands



Universal Tablet Mount
(shown on traditional music stand)



Large Move & Store Cart

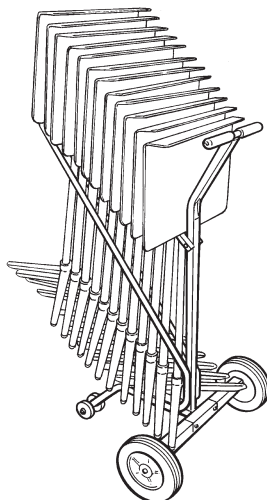

Small Move & Store Cart

Wenger®

JRCLANCY

GEARBOSS®

© 2024 Wenger Corporation
USA/2024-03

Minnesota Location

Wenger Phone 800.4WENGER (493-6437) Wenger Worldwide +1.507.455.4100 | Parts & Service 800.887.7145 | wengercorp.com
GearBoss Phone 800.493.6437 | gearboss.com
555 Park Drive, PO Box 448 | Owatonna | MN 55060

New York Location

J.R. Clancy Phone 800.836.1885 JR Clancy Worldwide +1.315.451.3440 | jrclancy.com | 7041 Interstate Island Road | Syracuse | NY 13209