

Basic Instructions only!
For more detailed product information, refer to the
Rehearsal Resource Center Assembly Instructions 121B021.

⚠ CAUTION
Make sure anyone assembling, installing or using this product has read and understands these instructions.

⚠ CAUTION
Failure to comply with Warnings and Cautions in this document or on the equipment can result in damage to property or injury.

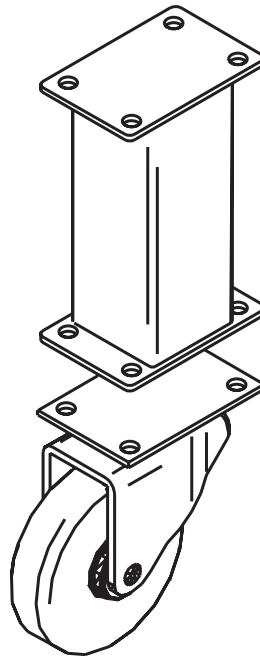

Contents

Required Tools	2	Parts List	2
Supplied Hardware	2	Assembly	2



Visit the Rehearsal Resource Center web page at wengercorp.com for more information.

Note: Please read and understand these instructions before proceeding.
Note: If you need additional information, contact Wenger Corporation using the information below.

Required Tools

The use of a power driver is not recommended.

- 1/2" open end wrench
- 5 mm and 5/32" hex wrench
- 1/2" socket and ratchet (optional)

Supplied Hardware

Some hardware shipped with the option and others are part of the unit assembly.

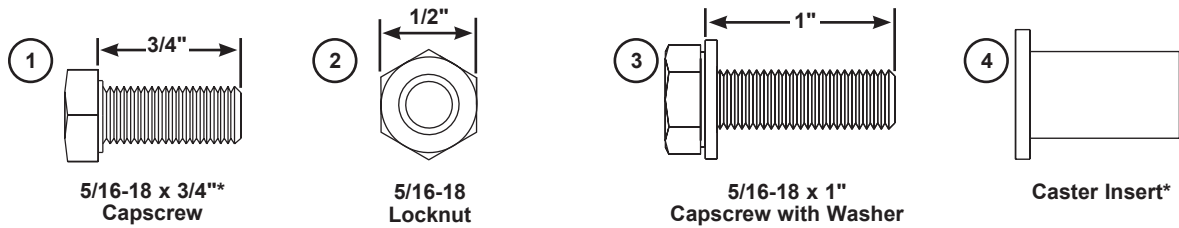

^{*} Shipped with unit assembly

Parts List

Item	Description	Item	Description
1	5/16-18 x 3/4" Capscrew ^{**}	5	Caster Assembly ^{**}
2	5/16-18 Lock Nut	6	Leg Extension
3	5/16-18 x 1" Capscrew	7	5 mm Hex Wrench ^{**}
4	5/16-18 Caster Insert ^{**}		

^{**} Included in unit assembly

Assembly

Before assembling the leg extensions, do the following.

1. Read and understand this assembly instruction.
2. Remove all items from the shipping cartons and make sure that all parts are present. Item numbers refer to the parts list on above.
3. Inventory the hardware package and make sure that all required hardware is present. Discard any items not used during the assembly.

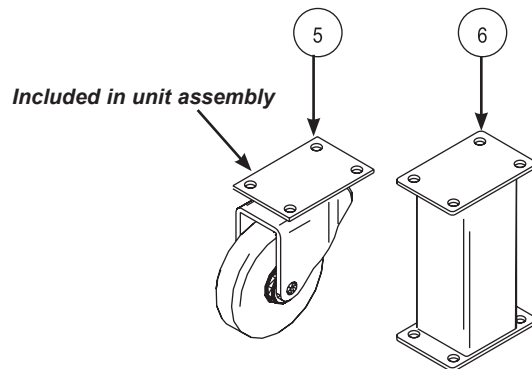

Assembly (continued)

1. With two people working together, carefully lift the unit assembly from the pallet and place it onto its backside with the shipping cap underneath.

CAUTION

Two people must always work together when lifting or moving the unit assembly.

WARNING

Dropping the unit assembly can result in serious damage or injury.

Unit Assembly Backside

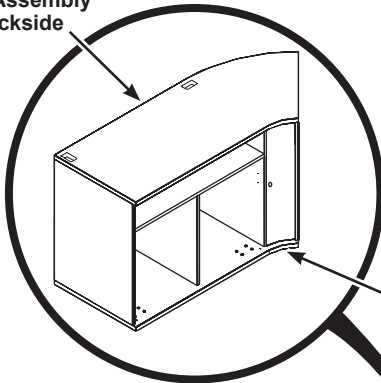

Unit Assembly Bottom Surface

Unit Assembly Top Surface

Curved End

Unit Assembly Bottom Surface

Drawer Unit Assembly Backside

Caster 7/16" Clearance Holes

Assembly (continued)

Assemble the caster assemblies (5) and optional leg extensions (6) to a unit assembly as follows.

2. With the unit assembly backside on the floor (front surface facing upward), align the leg extension clearance holes (6) to four 7/16" clearance holes on the bottom surface as shown in the illustration below.

NOTICE

If casters are already mounted to the unit assembly, first remove all five casters using the hex wrench (7) and a 1/2" open end wrench. Save all of the capscrews and inserts.

3. Insert a caster insert (4) into one of the 7/16" clearance holes.
4. Using a 5 mm hex wrench (7) to keep the caster insert (4) from turning, insert a capscrew (3) through the leg extension clearance hole and hand tighten until the capscrew lock washer contacts the leg extension (6). Once the lock washer makes contact, the caster insert (4) can be fully tightened by hand with the hex wrench (7).
5. Repeat steps 3 and 4 with three additional capscrews (3).
6. Assemble the four remaining leg extensions (6) to the unit assembly in the same manner (repeating steps 3 to 5).
7. Assemble all five caster assemblies (5) to the leg extensions with four capscrews (1) and four lock nuts (2) each. Use two 1/2" open end wrenches or one open end wrench and one socket and ratchet.
8. With two people working together, lift the unit assembly upward and then place it onto the floor with caster assemblies resting on the floor.

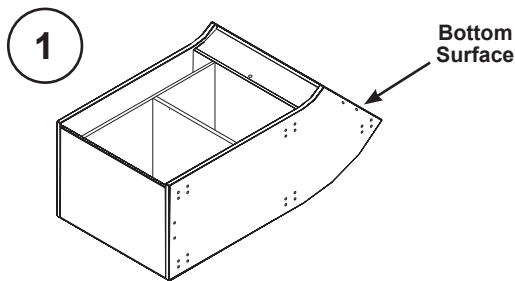

Right curved unit assembly shown

