

# Rehearsal Resource Center

- 121C001.\_ (243 lb) (110 kg) Left Curved Unit with Drawer or Stereo Rack Option
- 121C002.\_ (243 lb) (110 kg) Right Curved Unit with Drawer or Stereo Rack Option
- 121C003.\_ (2x 243 lb) (2x 110 kg) Twin Set - One each Left and Right Curved Unit with Drawer or Stereo Rack Options
- Overall dimensions: 28" deep x 39-1/2" high x 65-3/8" long (711 x 1003 x 1661 mm)
- Overall footprint: Wraparound Configuration: 75-1/2" wide x 75-1/2" deep (1918 x 1918 mm)  
Straight Configuration: 130-3/4" wide x 25-1/2" deep x 39-1/2" high (3321 x 648 x 1003 mm)
- Top, bottom and interior panels constructed of 1-1/8" (29 mm) thick thermofused composite wood with polyester laminate finish in graphite
- Side and interior panels constructed of 3/4" (19 mm) thick formaldehyde free industrial grade composite wood with polyester laminate finish in Wenger standard colors
- Rack mountable rails and three shelves included (Stereo Rack Option only)
- six-outlet power strip included with 15' (4572 mm) power cord, rated 15 amp, 120VAC, UL listed (Stereo Rack Option only)
- Top counter space measures 25-1/4" deep x 65-3/8" long (641 x 1661 mm)
- Drawer Option includes two 18-gauge steel pull-out drawers 17" wide x 18" deep x 3-1/2" high (432 x 457 x 89 mm) in black finish
- Includes upper storage compartment
- Two lockable rear service doors for wiring and cabling access
- Each unit includes five 4" (102 mm) diameter swivel casters
- Two wire grommets included in top panel for routing of cables
- Each unit includes a lockable storage compartment
- Units will lock together for straight across or wrap-around configuration
- Rolls through standard 3' (914 mm) doorway
- UL GREENGUARD Certified - Product certified for low chemical emissions: [ul.com/gg](http://ul.com/gg) - UL 2818
- Environmental attributes and LEED compliance for this product can be found at [www.wengercorp.com/GREEN](http://www.wengercorp.com/GREEN) or by contacting your Wenger representative
- Five-year warranty

### Optional Accessories

#### Folio Insert

- 121B105 (26 lb) (12 kg) set of two
- Pass-through slots for handouts, assignments, etc
- Includes three slots at 2" high x 18-3/4" wide (51 x 476 mm)

#### Locking Security Panels

- 121B101.\_ (19 lb) (9 kg) Lower door
- 121B102.\_ (7 lb) (3 kg) Upper door
- Doors are constructed of 3/4" (19 mm) industrial grade particleboard in polyester laminate finish in Wenger standard colors

#### Leg Extensions

- 121B103 (10 lb) (5 kg) set of five
- Includes five tubular steel leg extensions for use with 12" high (305 mm) podiums
- Adds 6" (152 mm) to height of Rehearsal Resource Center

#### Speaker Shelves

- 121B106.\_ (13 lb) (6 kg) set of two
- Shelves are 13-5/8" wide x 15-9/32" deep x 3/4" high (346 x 388 x 19 mm)
- Fold down flat against unit for storage and transport
- Shelves are constructed of 3/4" (19 mm) industrial grade particleboard in polyester laminate finish in Wenger standard colors

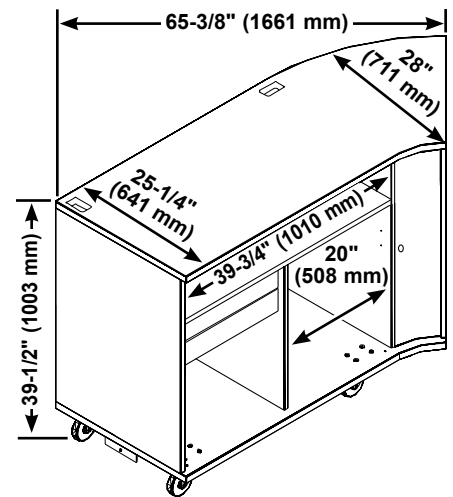

Right Curved Unit Assembly  
(Shown with Drawer Option)

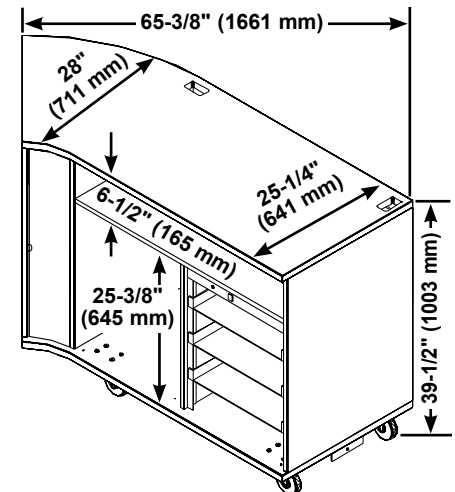

Left Curved Unit Assembly  
(Shown with Stereo Rack Option)



© 2019 Wenger Corporation  
USA/2019-04/W

