

Student Chair

- 0930000 Black finish frame, 14 lbs (6.4 kg).
- 0930001 Chrome finish frame, 14 lbs (6.4 kg).
- Black powder-coat paint finish frame for maximum durability. Chrome finish frame is also available
- Black high impact 1/8" (3 mm) thick textured polypropylene seat and back.
- Music posture design, with seat pan rise of 4-1/2° forward of pelvic area that creates a thigh to backrest angle of 97°, allowing musicians to sit in a posture equivalent to standing, thus freeing the diaphragm.
- 16-gauge 7/8" (22 mm) square tube frame, and 14-gauge 7/8" (22 mm) square tube rear crossmember designed and welded to give support around entire outer edge of both seat and back.
- Available in heights of 15-1/2" (394 mm), 16" (406 mm), 17" (432 mm), 17-1/2" (445 mm), 18-1/2" (470 mm) and 19-1/2" (495 mm).
- Chairs stack for compact storage, up to 18 chairs on a cart; 8 chairs without a cart.
- If chairs are equipped with the Ganging Clamp Accessory, they can be stacked no more than 4 high.
- Durable, specially designed floor glides provide stability when seated and ease of movement when arranging chairs.
- ANSI/BIFMA x 5.1-2002.
- California Technical Bulletin 133 compliant.
- UL GREENGUARD Certified - Product certified for low chemical emissions: ul.com/gg - UL 2818.
- Environmental attributes and LEED compliance for this product can be found at www.wengercorp.com/GREEN or by contacting your Wenger representative.
- Five-year warranty.

Chair Height	A*	B	C	D
15-1/2" (394 mm)	15-1/2" (394 mm)	21-1/4" (540 mm)	19-3/4" (502 mm)	31-3/8" (797 mm)
16" (406 mm)	16" (406 mm)	21-1/2" (546 mm)	19-3/4" (502 mm)	31-7/8" (810 mm)
17" (432 mm)	17" (432 mm)	21-15/16" (557 mm)	19-7/8" (505 mm)	32-7/8" (835 mm)
17-1/2" (445 mm)	17-1/2" (445 mm)	22" (559 mm)	19-7/8" (505 mm)	33-1/4" (845 mm)
18-1/2" (470 mm)	18-1/2" (470 mm)	22-5/8" (575 mm)	19-15/16" (506 mm)	34-1/4" (870 mm)
19-1/2" (495 mm)	19-1/2" (495 mm)	23" (584 mm)	20" (508 mm)	35-1/4" (895 mm)

*Dimension "A" measures frame height, not seat height.

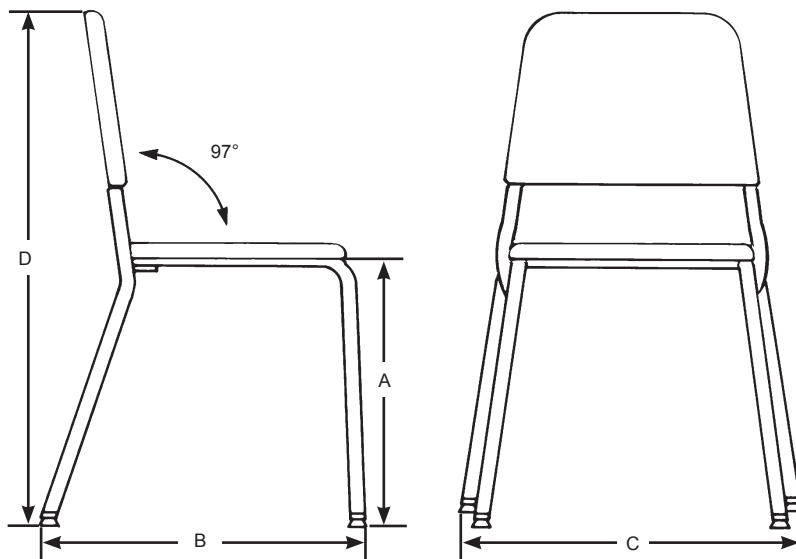

Available accessories listed on next page.

Accessories Include:

Folding Tablet Arm

- Right-hand: 0939014 8.5 lbs (3.9 kg) Left-hand: 0939015 8.5 lbs (3.9 kg).
- Pebble laminate surface, 13-3/4" x 17" (349 x 432 mm).
- 14-gauge support assembly with Black powder-coat paint finish.
- Chairs cannot be stacked with this accessory attached.

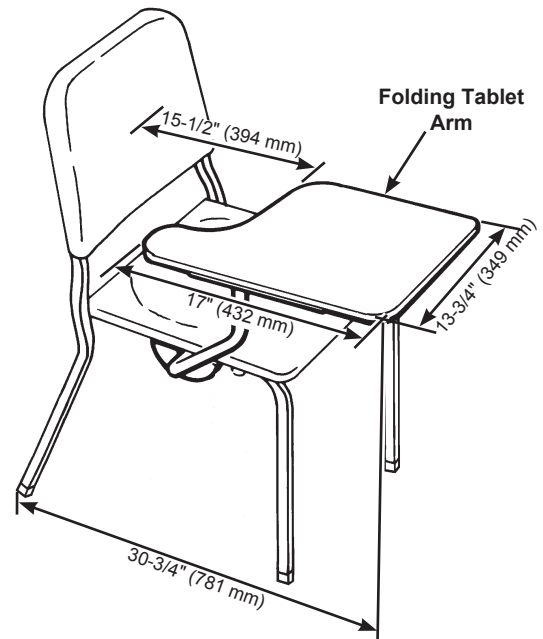

Book/Music Storage Rack

- Under-chair: 054L286 2 lbs (0.9 kg).
- 3/16" (4.8 mm) diameter solid steel rod construction.
- Chairs cannot be stacked with this accessory attached.

Tuba Rest

- 054A160 3.5 lbs (1.6 kg).
- Thru-bolted 16-gauge steel frame construction supports the full weight of the tuba.
- Height and depth adjustable.
- Vinyl protective coating.
- Can be added at any time.
- Chairs cannot be stacked with this accessory attached.

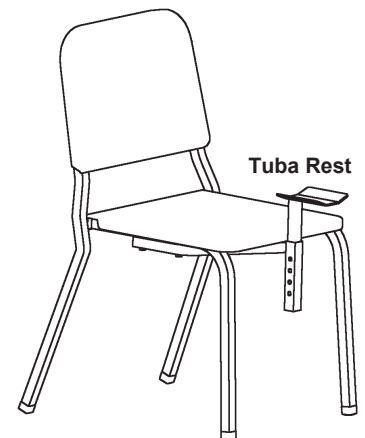

Sousaphone Holder

- 054B159 11 lbs (5 kg).
- 14-gauge steel support frame and 16-gauge steel uprights.
- Supports and helps balance the sousaphone. Can be used for storage.
- Adjustable height.
- Vinyl protective coating.
- Can be added at any time.
- Chairs cannot be stacked with this accessory attached.

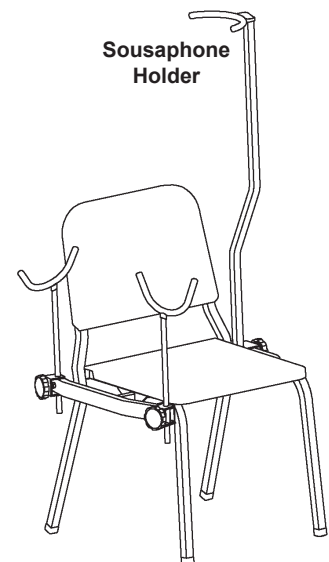

Move 'N Store Cart

- 127A261 30 lbs (13.6 kg).
- Stack, move and store up to eighteen Student Chairs.
- 16-gauge steel construction with easy-roll casters.

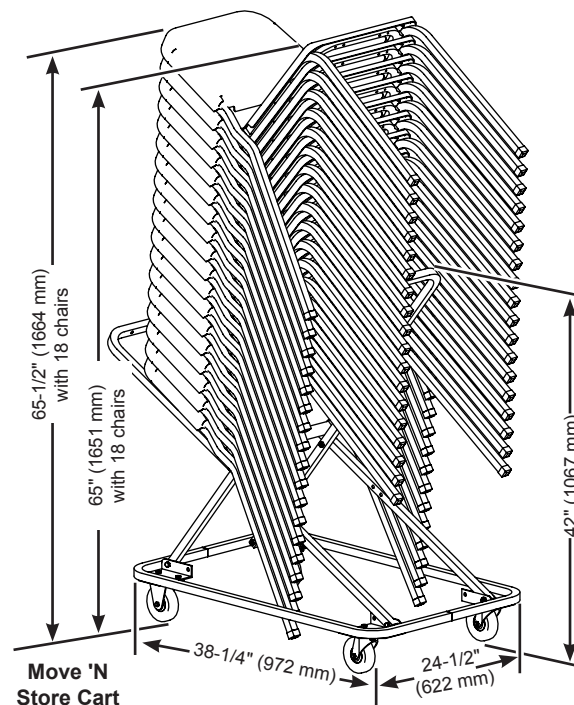

Ganging Clamps

- 190A059.
- Molded polycarbonate.
- Used to connect chairs together.

Dust Cover

- 054D500.
- Vinyl coated polypropylene.
- For use with chairs stacked on cart.

Wenger

JRCLANCY

GEARBOSS

© 2017 Wenger Corporation
USA/2017-12/W



WENGER CORPORATION

Phone 800.4WENGER (493-6437) Worldwide +1.507.455.4100 | Fax 507.455.4258 Worldwide +1.507.774.8576
Parts & Service 800.887.7145 | Canada Office 800.268.0148 | Web wengercorp.com | 555 Park Drive, PO Box 448 | Owatonna | MN 55060-0448

JR CLANCY

Phone 800.836.1885 Worldwide +1.315.451.3440 | Fax 877.836.1885 Worldwide +1.315.451.1766 | Web jrclancy.com
7041 Interstate Island Road | Syracuse | NY 13209-9713

GEARBOSS

Phone 800.493.6437 | email gearboss@wengercorp.com | Web gearboss.com | 555 Park Drive, PO Box 448 | Owatonna | MN 55060-0448