

Transcend® Classroom

Transcend® Technology in the music classroom or rehearsal space provides acoustic enhancement, Bluetooth playback, auxiliary input control, and instantaneous record and playback in one system that helps ensembles grow faster and perform with confidence.

- Ideal for music rehearsal rooms, large ensemble rooms, sound stages, black box theatres, cafeteriums and small performance spaces
- Creates a space where performers can rehearse in the acoustics of performance areas when the actual performance space is not available
- Includes eight preset environments, Studio A, Studio B, Recital Hall, Chamber Hall, Concert Hall, Great Hall, Chapel, Arena and Grand Cathedral, plus one customizable setting of specific performance space determined by the customer
- Integrated record/playback feature, which is an effective teaching tool supporting immediate self-assessment; the high-quality recordings may be saved to internal storage or directly onto external USB (type-C) drive
- Intuitive and easy to use touch screen control, with wireless control options
- Bluetooth® wireless audio, enabling users to seamlessly play audio content from any Bluetooth compatible device
- Offers three stereo auxiliary inputs (two balanced, one RCA) for seamless integration with external AV systems
- Complete turn-key installation, including all electrical components, system tuning, and wiring/mounting of all speakers and microphones. Also includes installation of acoustical absorber panels and NRC rated 0.95 acoustical ceiling tiles if needed
- System includes lockable, front and rear access, portable or wall-mounted component rack for all system components, including Transcend digital signal processor, power sequencer, amplifiers, and ventilation fan
- Five-year warranty

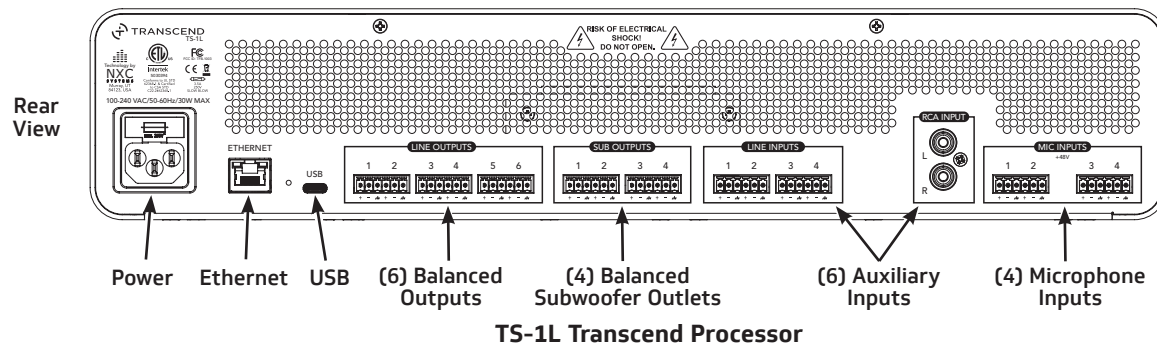
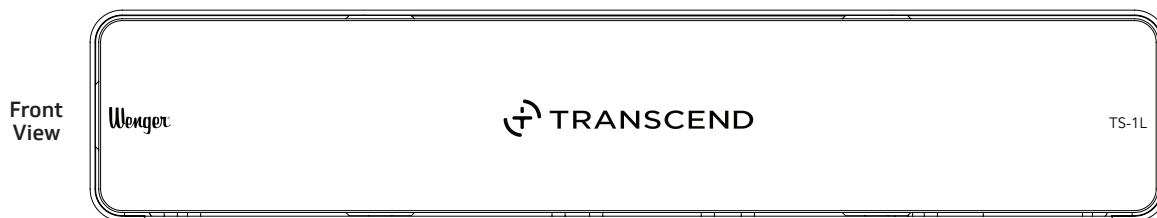
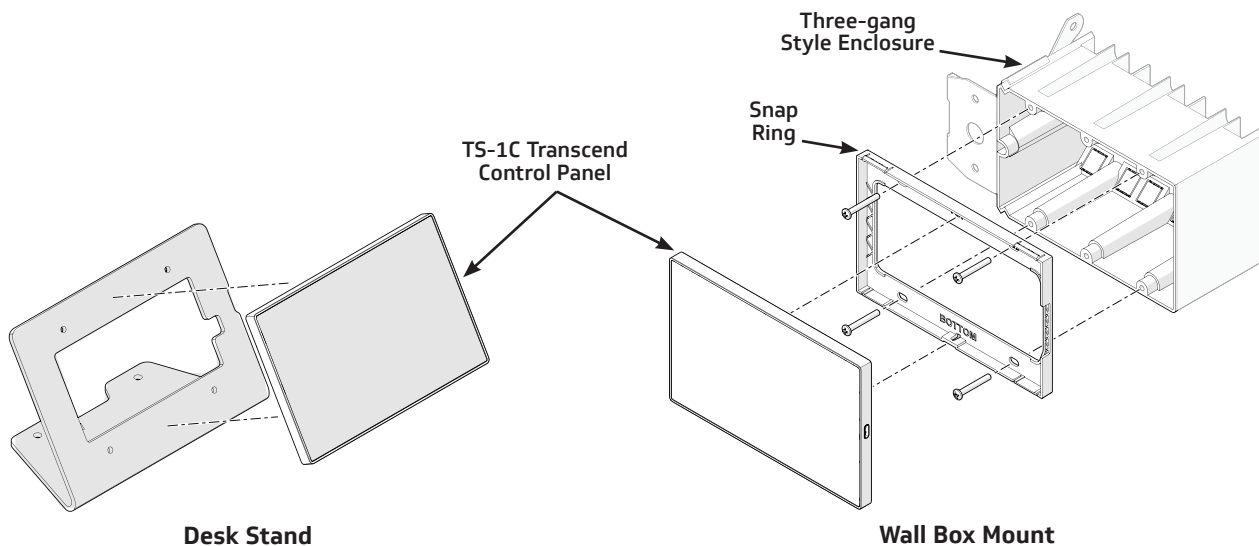

Core System Components

Wenger TS-1L Transcend Processor

- Fully-integrated active acoustics, Bluetooth, instantaneous record and playback with end-user automatic calibration
- Power requirements: 100-240 V, 50/60 Hz, 30 W
- Operating conditions: 0° to 40° C (32° to 104° F)
- Data interface:
 - 1 RJ45, POE+ out or Network interface
 - 1 USB type C
 - Bluetooth
- Internal storage: 131 minutes of recorded audio (44.1 kHz wav)
- Balanced line inputs: 1 stereo
 - SNR (A): 110 dBA
 - THD+N: 0.002%
- Balanced line outputs:
 - SNR(A): 114 dBA
 - THD+N: 0.002%
- Dimensions: 17.4"w x 3.5"h x 10.3"d (442 x 89 x 272 mm)

Wenger TS-1C Transcend Control Panel

- Screen: 5.5" (140 mm) IPS, capacitive touch, POE+
- Form factor: US 3-gang duplex
- USB-C pass-through data interface, side mount
- Dimensions: 6.25"w x 1.17"d x 4.05"h (159 x 30 x 103 mm)
- Security set screw: #4-40 x 1/4"

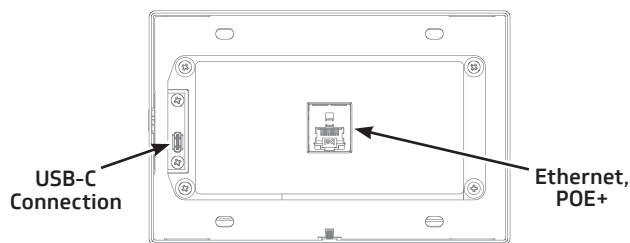

TS-1C Transcend Control Panel

Standard Configured Components

Crown DriveCore Install Series Amplifiers

Crown ComTech DriveCore Series Amplifiers

Wall-Mount Speakers, JBL Control 28-1L (Typical)

- Frequency response: (-10db) half-space wall: 45 Hz – 16 kHz
- Sensitivity: 91 db, 1W, 1m
- Continuous program power capacity: 240 watts
- Wall mounting brackets included
- Ball-mount adjustment
- Dimensions: 11.1"w x 15.2"h x 8.6"d (282 x 386 x 219 mm)
- Weight: 13.5 lb (6.1 kg)

Ceiling Speakers, Control 47C/T (Typical)

- Frequency response: (-10db) half-space wall: 70 - 20kHz
- Sensitivity: 89db SPL, 1W, 1m
- Continuous program power capacity: 150 watts
- Grille, back can, and tile rails included
- 10" diameter (254 mm)
- Weight: 12 lb (5.4 kg)

Microphones, Rode NT5 (Typical)

- Transducer type: pre-polarized condenser microphone
- Frequency response: 20 – 20k Hz
- Equivalent Noise: 16 dBA
- Maximum SPL: 143 dB

Equipment Rack (Typical)

- Middle Atlantic RFR Series Reference Furniture Rack

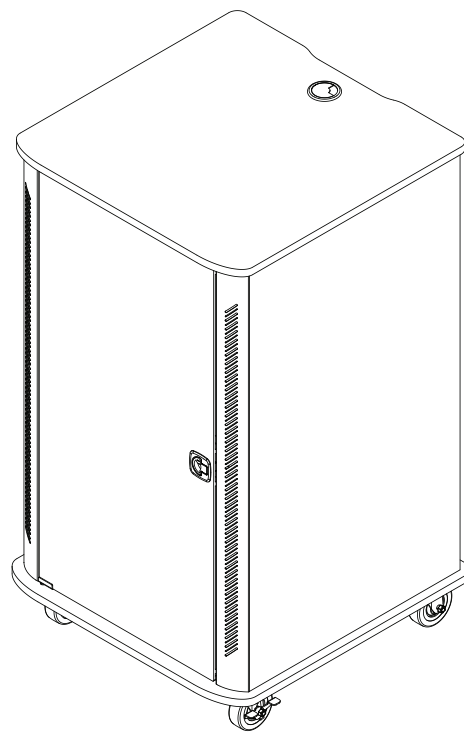

Equipment Rack



© 2026 Wenger Corporation
USA/2026-01

Minnesota Location

Wenger Phone 800.4WENGER (493-6437) Wenger Worldwide +1.507.455.4100 | Parts & Service 800.887.7145 | wengercorp.com
GearBoss Phone 800.493.6437 | gearboss.com
555 Park Drive, PO Box 448 | Owatonna | MN 55060

New York Location

J.R. Clancy Phone 800.836.1885 JR Clancy Worldwide +1.315.451.3440 | jrclancy.com | 7041 Interstate Island Road | Syracuse | NY 13209