

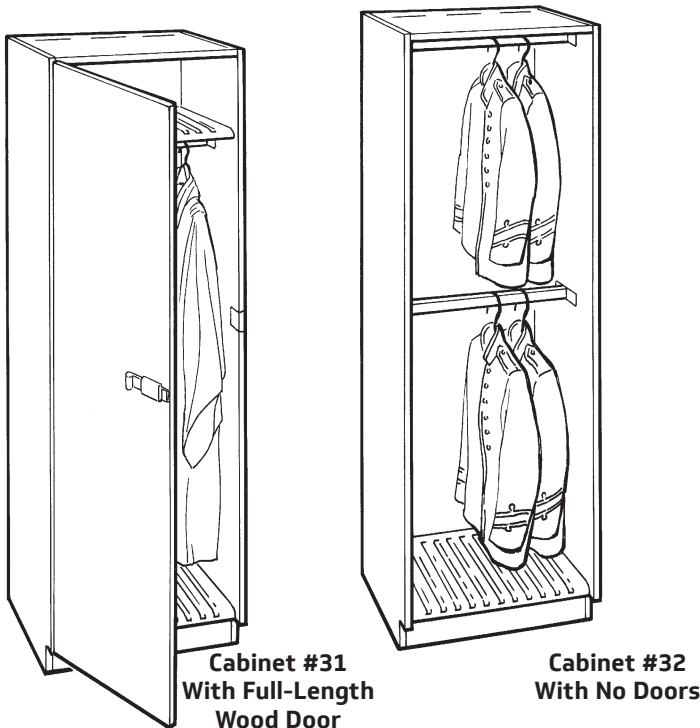

# UltraStor<sup>®</sup> Robe and Uniform Storage Cabinets

- Variety of styles tailored to different storage needs
- Wall panels are 3/4" (19 mm) thick industrial grade composite wood with no added formaldehyde and polyester laminate finish in Wenger standard colors
- Patented shelves are blow-molded polyethylene mounted with self-lock shelf supports
- Grooved shelves allow air to circulate around items being stored
- Edging is 1/8" (3 mm) radiused PVC
- Heavy-gauge steel hanging rods hold up to 200 lb (90 kg) evenly distributed
- Door options for cabinets #31, #32 and #33
  - Full-length wood door - same construction as wall panels
  - Full-length grille door - welded steel grille construction with powder-coat paint finish
  - No door
- Door options for cabinets #34, #35 and #36:
  - Full-length double wood doors - same construction as wall panels
  - Full-length double grille doors - welded steel grille construction with powder-coat paint finish
  - No door
- Cabinets have adjustable steel leveling glides for uneven floors
- Ventilation holes in casework for circulation help dissipate moisture and aid air circulation
- Doors include heavy-duty 5-knuckle institutional ANSI/BHMA A156.9, Grade 1 hinge, through - bolted to cabinet wall
- Locking slide bolt with strike plate designed for padlocks with 3/4" (19 mm) maximum vertical shackle clearance
- UL GREENGUARD certified - product certified for low chemical emissions: [ul.com/gg](http://ul.com/gg) - UL 2818
- Ten-year warranty

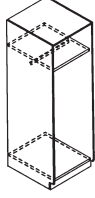
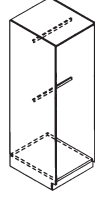
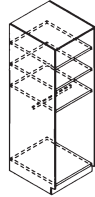
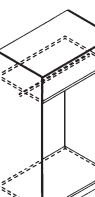
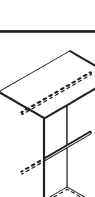

	<p><b>#31</b> 27-1/2"w x 29-1/4"d x 85-5/8"h (699 x 743 x 2175 mm) 239 lb (108 kg) Stores 11 uniforms or robes Upper shelf for additional storage</p> <p><b>Compartment sizes:</b> 25-1/2"w x 27-3/8"d x 11-1/4"h (648 x 695 x 286 mm) 25-1/2"w x 27-3/8"d x 65-3/8"h (648 x 695 x 1661 mm)</p>
	<p><b>#32</b> 27-1/2"w x 29-1/4"d x 85-5/8"h (699 x 743 x 2175 mm) 233 lb (106 kg) Stores 22 uniforms</p> <p><b>Compartment sizes:</b> 25-1/2"w x 27-3/8"d x 77-7/8" h (648 x 695 x 1978 mm)</p>
	<p><b>#33</b> 27-1/2"w x 29-1/4"d x 85-5/8"h (699 x 743 x 2175 mm) 252 lb (114 kg) Stores 11 uniforms and 12 hats</p> <p><b>Compartment sizes:</b> 25-1/2"w x 27-3/8"d x 11-1/4"h (648 x 695 x 286 mm) 25-1/2"w x 27-3/8"d x 39-5/8"d (648 x 695 x 1007 mm)</p>
	<p><b>#34</b> 48-1/2"w x 29-1/4"d x 85-5/8"h (1232 x 743 x 2175 mm) 454 lb (206 kg) Stores 20 robes or uniforms Upper shelf for additional storage</p> <p><b>Compartment sizes:</b> 46-1/2"w x 27-3/8"d x 10-1/4"h (1181 x 695 x 260 mm) 46-1/2"w x 27-3/8"d x 63-5/8"h (1181 x 695 x 1616 mm)</p>
	<p><b>#35</b> 48-1/2"w x 29-1/4"d x 85-5/8"h (1232 x 743 x 2175 mm) 445 lb (202 kg) Stores 40 uniforms</p> <p><b>Compartment sizes:</b> 46-1/2"w x 27-3/8"d x 76-1/2"h (1181 x 695 x 1943 mm)</p>
	<p><b>#36</b> 48-1/2"w x 29-1/4"d x 85-5/8"h (1232 x 743 x 2175 mm) 479 lb (217 kg) Stores 20 uniforms and 24 hats</p> <p><b>Compartment sizes:</b> 46-1/2"w x 27-3/8"d x 10-1/4"h (1181 x 695 x 260 mm) 46-1/2"w x 27-3/8"d x 38-3/8"h (1181 x 695 x 975 mm)</p>

Note: Doors must be included at the time of ordering as they can not be installed later.